

Figure 4. Removing Battery Cover

C. Opening the Battery Compartment: To remove the cover, press at circle 3 and slide the cover toward circle 4. Keep your fingers out of the circle 4 zone to avoid a pinch.

D. Changing Microphone Channel: Change the channel if you experience interference from another mic or a nearby wireless local area network (LAN).

1. Turn on the microphone and the receiver,
2. Open the BATTERY COVER and locate the CHANNEL KNOB.
3. Use a screwdriver to rotate the knob to a different channel.
4. There are 16 detents on the knob, one for each channel.
5. When you rotate the knob, the MIC ACTIVE LED on the receiver will blink once to indicate that the microphone is reconnected to the receiver.
6. You do not need to turn off or reset the microphone or the receiver.

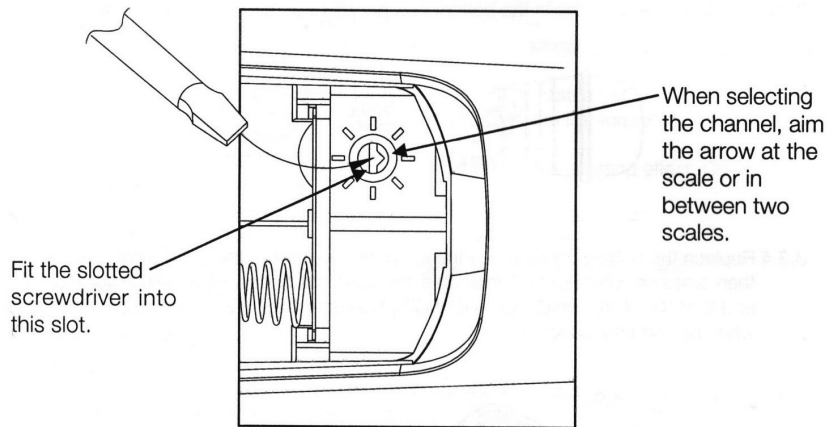

Figure 5. Changing the Microphone Channel

Lampifier.com
5348 N. Tacoma Avenue
Indianapolis, IN 46220

317-225-5509 phone
317-222-1327 fax

www.Lampifier.com

help@Lampifier.com

Lampifier® Anti Drop-Out Dual Wireless Microphone System



Thank you for choosing the Lampifier Anti-Drop Out Wireless Microphone system. Please read this manual carefully before using the device.

This system is intended for a wide range of applications such as professional music performances, karaoke, meetings, and religious services.

A. Carton Contents:

- One Model 1231R Digital Wireless Receiver
- Two Wireless Microphones
- One 7.5V DC Power Adaptor
- One 1/4 inch phone-plug cable
- One User's Manual

One Optional Model 1231C 1/4 Inch to Dual XLR Output Adapter Cable

Optional Adapter Cable



December 2012

B. Parts Identification:

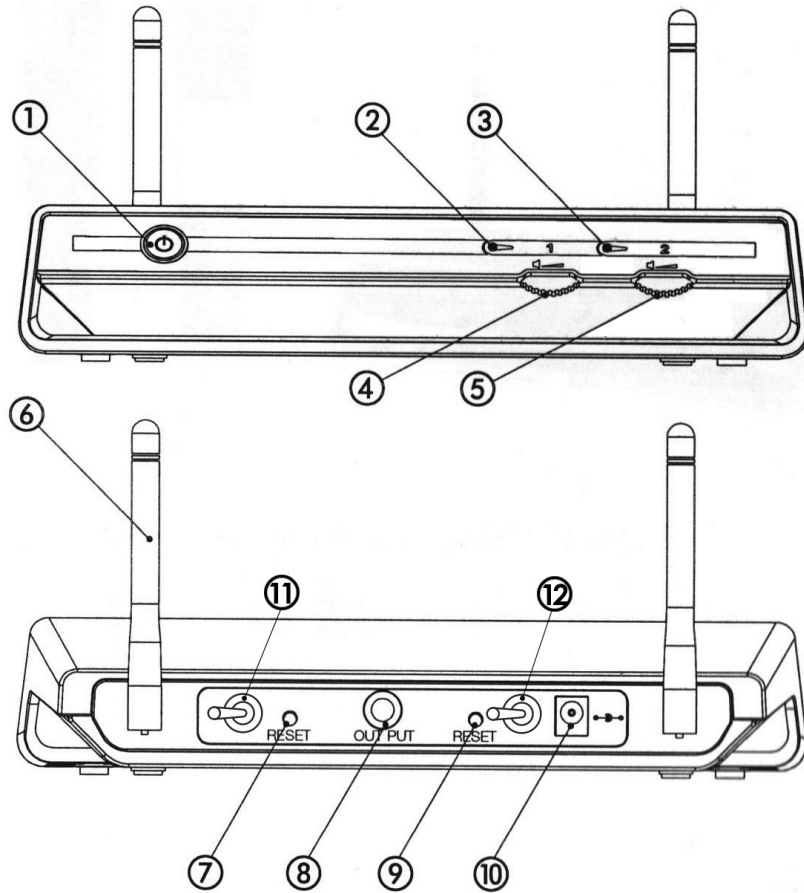

Figure 1. Receiver

1. POWER SWITCH - Press and hold 2 to 3 seconds to turn ON or OFF.
2. MIC 1 ACTIVE / OVERLOAD LED - Glows red when microphone 1 is turned on and ready for use. Flashes when mic 1 LAMPIFY KNOB needs to be turned down to prevent signal clipping. (See figure 2.)
3. MIC 2 ACTIVE / OVERLOAD LED - Same as above for microphone 2.
4. VOLUME 1 KNOB - Turn this knob to change the output volume of mic 1.
5. VOLUME 2 KNOB - Same as above for microphone 2.
6. ANTENNA
7. RESET BUTTON - For factory use only.
8. 1/4" OUTPUT JACK - Both mics signals are mixed into this mono output. Use the optional 1231C Adaptor Cable to convert the output into two independent balanced XLR outputs.
9. RESET BUTTON - For factory use only.
10. DC POWER - Connects to the AC Adaptor for 7.5V DC, center pole is +.
11. MODE SWITCH 1 - Selects mic 1 operating mode: Lampify, Mute, Normal.
12. MODE SWITCH 2 - Same as above for microphone 2.

1. BALL GRILL - Protects the microphone cartridge and reduces wind noise.
2. POWER SWITCH - Press to turn the microphone ON. Press and hold 2 to 3 seconds to turn OFF. If the green LED flashes, replace the batteries.
3. HOUSING - The wireless transmitter and batteries are inside.
4. ANTENNA - Operates at 2.4GHz, the same band as wireless LAN.
5. BATTERY COVER - Remove this cover to access batteries and controls.
6. BATTERY COMPARTMENT - Two "AA" batteries are required.
7. CHANNEL KNOB - Rotate this knob to select one of 16 channels.
8. LAMPIFY KNOB - When the receiver is in the LAMPIFY mode, turn up this knob to increase dynamic compression of the audio signal. When the receiver is in the NORMAL mode, this knob is a volume control. In either mode, if the red OVERLOAD LED on the receiver flashes, turn down this knob to avoid sound distortion caused by signal clipping. To reduce feedback at loud volume, turn down this knob. At extreme volume, you can also set the receiver to NORMAL mode to reduce feedback.
9. RESET BUTTON - For factory use only.

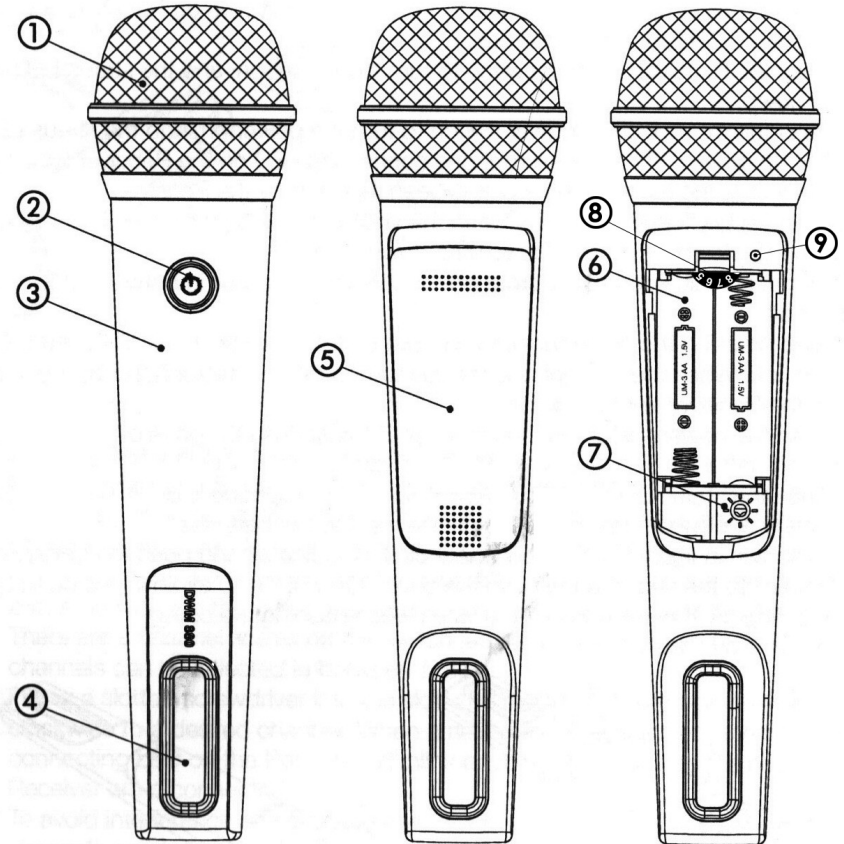

Figure 2. Microphone (Transmitter)